

INSTRUCTION SHEET
POLYURETHANE PRESS-IN CONTROL ARM BUSHING SET - FRONT
S1-2004 1992-2000 SC300/SC400 (JZZ31/UZZ30)

CAUTION! Due to the nature of the parts being installed, it is highly recommended that this installation be performed by a qualified mechanic or technician!

UPPER CONTROL ARMS

1. Remove the upper control arms from the vehicle as per factory service manual instructions. Take extreme care not to damage the ball joints - especially the ball joint threads/nuts/boots.
2. The original rubber bushings should be removed with a hydraulic press.
CAUTION! - Care must be taken not to damage the control arms. The insides of the original bushing mounting areas must be completely free of all excess rubber, dirt, corrosion, etc. before installing the new bushings. This can be accomplished with a wire brush, solvent and/or fine grit sandpaper.
3. Grease new bushings and insert them into the control arms.
4. Thoroughly grease inner bushing surfaces and supplied metal sleeves and insert sleeves into the bushings.
5. **Grease the faces of the bushings (IMPORTANT!)** and reinstall the control arms. Be sure that any areas that contact the bushing faces are free from any dirt or corrosion before installing the control arms. These areas should also be greased prior to control arm installation.
6. Torque all hardware to factory service manual specifications.
(Control arm bolts 121 lb-ft, ball joint nuts 76 lb-ft)

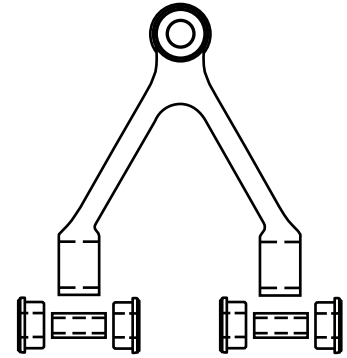

Upper Control Arm

LOWER CONTROL ARMS

1. If the vehicle will not be aligned immediately after installation, be sure to mark current alignment settings on all four adjusting cam bolts before any work is started.
2. Remove the lower control arms from the vehicle as per factory service manual instructions. Take extreme care not to damage the ball joints - especially the ball joint threads/nuts/boots.
3. The original shell/bushing assemblies should be removed with a hydraulic press.
CAUTION! - Care must be taken not to damage the control arms. The insides of the original bushing mounting areas must be completely free of all excess rubber, dirt, corrosion, etc. before installing the new bushings. This can be accomplished with a wire brush, solvent and/or fine grit sandpaper.
4. Using a hydraulic press, install new bushing shells as shown in illustration below.
5. Grease new bushings and install them from the outside as shown in the illustration below. Be sure that the flange of the bushing seats completely against the outer steel shell.
6. Thoroughly grease inner bushing surfaces and supplied metal sleeves and insert sleeves into the bushings.
7. **Grease the faces of the bushings (IMPORTANT!)** and reinstall the control arms. Be sure that the areas on the vehicle that contact the bushing faces are free from any dirt or corrosion before installing the control arms. These areas should also be greased prior to control arm installation.
Tip: Slightly chamfer the sharp corners/edges on the bottom of the aluminum crossmember with a file or grinder to allow the forward bushings to slide into position easier.
8. Torque all hardware to factory service manual specifications.
(Control arm bolts 166 lb-ft, ball joint nuts 92 lb-ft, shock absorber bolts 106 lb-ft, sway bar link nuts 47 lb-ft)

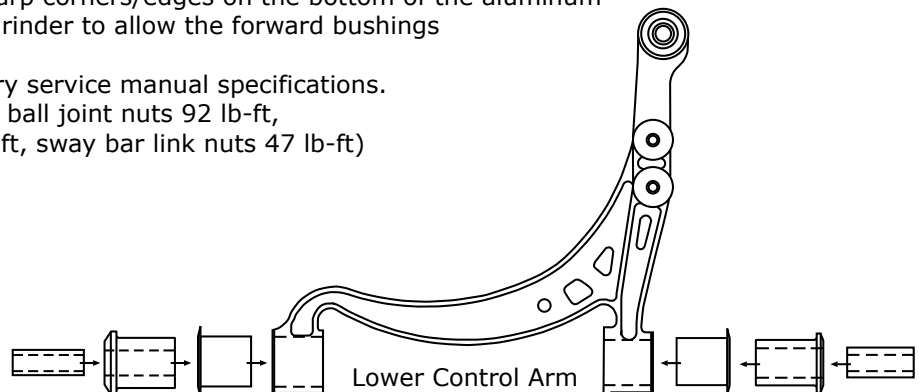

Lower Control Arm