

INSTRUCTION SHEET
REAR POLYURETHANE CONTROL ARM BUSHING KIT
S1-2003 1992-2000 SC300/SC400 (JZZ31/UZZ30)

CAUTION! Due to the nature of the parts being installed, it is highly recommended that this installation be performed by a qualified mechanic or technician!

UPPER CONTROL ARMS

1. Remove the upper control arms from the vehicle as per factory service manual instructions. Take extreme care not to damage the ball joints - especially the ball joint threads/nuts/boots.
2. Press out the original bushings/bearings using a press. **CAUTION! - Care must be taken not to damage the control arms!**
3. Grease 1.78"OD x .980"L urethane bushings and insert them into the control arms. (Be sure insides of arms are free from any dirt or corrosion before installing bushings).
4. Grease .875"OD x 2.015"L sleeves and insert them into the bushings.
5. **Grease the faces of the bushings (IMPORTANT!)** and reinstall the control arms. Be sure that the areas on the vehicle that contact the bushing faces are free from any dirt or corrosion before installing the control arms. These areas should also be greased prior to control arm installation.
6. Torque all hardware to factory service manual specifications.
(Control arm bolts 121 lb-ft, ball joint nuts 80 lb-ft)

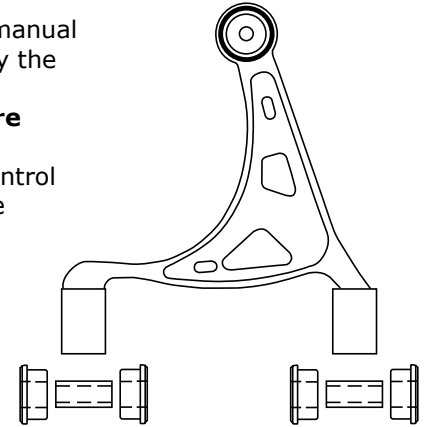

Upper Control Arm

LOWER CONTROL ARMS

1. If the vehicle will not be aligned immediately after installation, be sure to mark current alignment settings on all four adjusting cam bolts before any work is started.
2. Remove the lower arms from the vehicle as per factory service manual instructions. Take extreme care not to damage any of the ball joints - especially the ball joint threads/nuts/boots. (**NOTE:** Removal and replacement of one arm at a time is recommended).
3. Press out the original sleeves/bushings using a press. **CAUTION! - Care must be taken not to damage the control arms/components!**
4. Grease replacement urethane bushings and insert them into the corresponding control arm.

- | | |
|-----------------|----------------------------|
| No. 1 Lower Arm | 1.57"OD x .950"L bushings |
| No. 2 Lower Arm | 1.50"OD x 1.130"L bushings |
| Strut Rod | 1.82"OD x .860"L bushings |
| Spindle | 1.35"OD x .710"L bushings |

5. Grease replacement sleeves and insert them into the corresponding bushings.

- | | |
|-----------------|-------------------------|
| No. 1 Lower Arm | .875"OD x 1.93"L sleeve |
| No. 2 Lower Arm | .875"OD x 2.33"L sleeve |
| Strut Rod | .875"OD x 1.75"L sleeve |
| Spindle | .875"OD x 1.46"L sleeve |

6. **Grease the faces of the bushings (IMPORTANT!)** and reinstall the control arms. Be sure that the areas on the vehicle that contact the bushing faces are free from any dirt or corrosion before installing the control arms. These areas should also be greased prior to control arm installation.

7. Torque all hardware to factory service manual specifications.

- | | |
|-----------------|---|
| No. 1 Lower Arm | Bolt 136 lb-ft, ball joint nut 43 lb-ft |
| No. 2 Lower Arm | Bolt 136 lb-ft, ball joint nut 150 lb-ft,
shock absorber bolt 106 lb-ft,
sway bar link nut 26 lb-ft |

- | | |
|-----------|----------------|
| Strut Rod | Bolt 136 lb-ft |
| Spindle | Bolt 136 lb-ft |

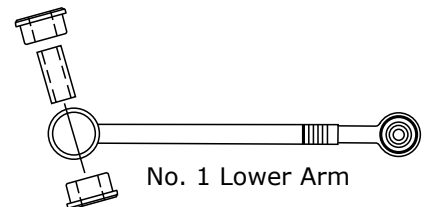

No. 1 Lower Arm

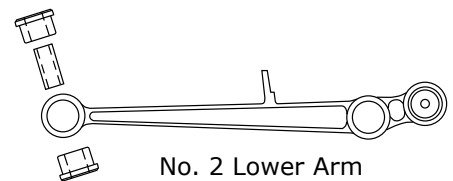

No. 2 Lower Arm

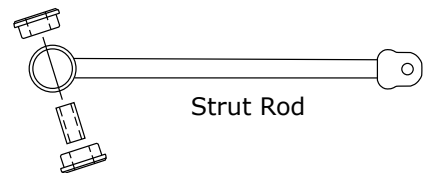

Strut Rod



Spindle